

Comparing LiFi and WiFi: Security, Limitations, Applications and Technology Requirements

Sharvari Kulkarni

Software Product Consultant, Siemens Ltd,
Vidyarthi Griha's College of Engineering, Pune University, Pune
sharvari29@gmail.com

Abstract

Li-Fi (Light- Fidelity) is known for its fast speed which has been developed for the effective use of light as a technology. Li-Fi, a next generation technology which is used in progression with Wi-Fi Technology. With the use of LED lights, Li- Fi becomes faster and flexible technology for data transmission through Wi-Fi. As light become an integral part of our life, it is available everywhere. It has been observed that data transfer through Li-Fi is much faster than Wifi, which is in bits. The main objective of this paper is on comparing a Li-Fi based system and analyzes its performance with respect to wifi technology. Also, the security issues, limitations, applications and technology requirements for implementing the technology. The use of this technology can minimize many problems of currently used data transfer technology.

Keywords: *Li-Fi technology, Wi-Fi Technology, Visual Light Communication (VLC), Wireless Data Transmission*

1. Introduction

In this modern era, technology savvy people can't live without internet where exchange of information through various mediums is happening every day. Exchange of information in the digital world is transforming the way for every individual to the highest extent. Day by day applications are arising with its distinctive features, requires more support from technology updates for high performance. But, what about the speed of transmission of data. With the growing transactions in technology, we expect higher performance. Here is one way to get this solved by using Li-Fi Technology. Li-Fi technology exploits the capabilities of a Light Emitting Diode (LED)

to serve the purpose of data transmission with greater reliability, security and accuracy. In 2011, Professor Harold Haas, University of Edinburg, UK, suggested the idea of Light Fidelity as "Data through illumination" where we use Visual Light to achieve the data

transmission. Visual Light can produce the transmission of rate of more than 10.

1.1 What is Li-Fi?

Li-Fi technology, a light-based communication technology, which is using the light waves instead of radio technology to deliver data.

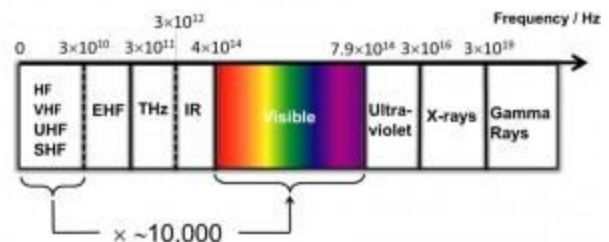

With the use of the visible light spectrum, Li-Fi technology can exchange data and unlock capacity, which is around 10,000 times greater than existing within the radio spectrum. The visible light spectrum is free, plentiful and unlicensed, mitigating the radio frequency spectrum crunch effect.

1.2 What is Wi-Fi?

Wireless technology has rapidly spread lately and you can get connected almost anywhere; at your place, at work, schools, in libraries, hotels, airports, and even in restaurants too.

Wireless networking is identified as WiFi or 802.11 networking because it covers the IEEE 802.11 technologies. The main benefit of WiFi is, it is compatible with almost every operating system, advanced printer game device, etc.

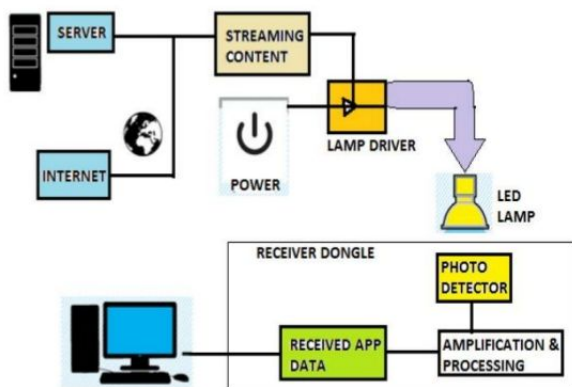

Figure: Working of Li-Fi

2. Security with Li-Fi

In a meeting room environment, the access area for each channel is the width of the light pool, and can be used by many users. Each user can get higher data rates than would be the case for an equivalent Wi-Fi channel. In Wi-Fi, every user or a group of users directly finishes for access to bandwidth. Which results into the more connections there are, the lesser the download speeds are for all. However, in the case of Li-Fi, with its large number of available access points, each pool of light gives full channel data rates with some simultaneous users. Again the benefit getting to each user is up to 1000 times higher rate of speed. In addition, and in contrast to radio waves, the light does not pass through the walls. So, there are minimal precautions to be taken to avoid leakage from

windows, etc., security is fundamentally improved as compared with Wi-Fi.

3. Limitations of Li-Fi

LiFi could be much faster than WiFi, but it possesses some critical limitations that will likely keep it from accepting worldwide. LiFi was introduced early in 2013. UK Researchers were able to transmit data at speeds up to 10Gbps using LEDs. LED bulbs produce steady output when fed a continuous current. Differing the current can dim the light up or down. The making of LiFi bulbs from a semiconductor device, means the current and resulting output can be altered at incredibly quick speeds. Data can be embedded in the modulations, which is then read by photodetectors and transmit back to regular electric current on the receiving end.

Here are a few limitations over Li-Fi

The Internet cannot be used without a light source. This could limit the areas and situations in which Li-Fi could be used.

- Li-Fi is used in visible light, and light cannot penetrate walls, the signal's range is restricted by physical barriers.
- Other sources of light may interfere with the signal. One of the biggest potential limitation is the interception of signals outdoors. Sunlight will restrict the signals and resulting in interrupted Internet.
- A whole new infrastructure would need to be constructed for Li-Fi.

4. Applications of Li-Fi

Li-Fi is used in various sectors such as Education, Medical, Aircraft, Underwater, and Disaster Management so on etc. Li-Fi applications are from public internet access via street lamps to auto-piloted cars which communicate through the headlights. Li-Fi applications are extending in the area of medical, power plants where Wi-Fi does not. Li-Fi is using light so it is safe in aircrafts and hospitals, where Wi-Fi can prone to interface with the radio waves, is banned. Even all the street lamps can be converted to Li-Fi lamps for transforming the data. So that, it could access the internet at any public area. Here listed some future applications of Li-Fi are as follows:

1) Medical: Because of radiation issues operation theatres do not allow Wi-Fi. Use of Wi-Fi at hospitals interferes with the mobile and computer blocks the signals for monitoring equipments. It may be dangerous to the patient's treatment. To resolve this issue Li-Fi is the

solution to access internet and to control medical equipments. Even it is helpful for robotic surgeries and other automated procedures.

2) Use in Sensitive Areas: For sensitive areas like power plant Wi-Fi is Power plants need fast, inter-connected data systems so that demand, grid integrity and core temperature (in case of nuclear power plants) can be monitored. Wi-Fi and many other radiation types are bad for sensitive areas surrounding the power plants. As compared with Wi-Fi, Li-Fi could offer safe, abundant connectivity for all areas of these sensitive locations. This can save money as compared to the currently implemented solutions. Also, the pressure on a power plant's own reserves could be lessened. Li-Fi can also be used in petroleum or chemical plants where other transmission or frequencies could be hazardous.

3) Cheaper Internet in Aircrafts: The passengers travelling in aircrafts get access to low speed internet at a very high rate. Also Wi-Fi is not used because it may interfere with the navigational systems of the pilots. In aircrafts Li-Fi can be used for data transmission. Li-Fi can easily provide high speed internet via every light source such as overhead reading bulb, etc. present inside the airplane.

4) Underwater applications: Underwater ROVs (Remotely Operated Vehicles) operate from large cables that transfer their power and allow them to receive signals from their pilots above. But the tether used in ROVs is not long enough to allow them to explore larger areas. If their wires were replaced with light — say from a submerged, high-powered lamp — then they would be much freer to explore. They could also use their headlamps to communicate with each other, processing data autonomously and sending their findings periodically back to the surface [1]. Li-Fi can even work underwater where Wi-Fi fails completely, thereby throwing open endless opportunities for military operations.

5) Disaster management: In times of disaster, Li-Fi can be used as a powerful communication such as earthquake or hurricanes. The average people may unaware of the protocols during such disasters. Subway stations and tunnels, common dead zones for most emergency communications, pose no obstruction for Li-Fi. Also, for normal periods, Li-Fi bulbs could give cheap high-speed Web access to every street corner.

6) Education: Li-Fi is the newest technology that can give fastest speed internet access. So, it can replace Wi-Fi at educational institutions and at companies so that all the

employees can use Li-Fi with the same speed intended in a particular area

7) Traffic management: Li-Fi can be used in traffic signals, which will communicate with the LED lights of the cars and can help in managing the traffic in a better manner and results into decrease number of the accidents. Also, LED car lights can alert drivers when other vehicles are close too.

8) Replacement for other technologies: Using radio waves Li-Fi doesn't work. So, it can be easily used in the areas where Wi-Fi, Bluetooth, Infrared, etc. are banned.

5. Technology Requirement

Li-Fi is a kind of Visible Light Communication (VLC) technology. VLC technology is an optical wireless data communications medium which uses visible light between 400 and 800 THz (780–375 NM) to transfer binary data in the form of light pulses. However, Wi-Fi is based on Radio Frequency (RF) technology which access a frequency within the electromagnetic spectrum associated with radio wave propagation.

The Future of Li-Fi

With faster connectivity and data transmission it's an interesting space for businesses. The integration of the internet of things devices and Li-Fi will allow a wealth of opportunities for retailers and other businesses too.

Li-Fi has reportedly been tested in Dubai, by UAE-based telecommunications provider, du and Zero1. Du claims to have successfully provided internet, audio and video streaming over a Li-Fi connection.

According to web reports it has been noted that Apple may develop future iPhones with Li-Fi capabilities. One Twitter user observed that within its iOS 9.1 code there were references to Li-Fi written as 'LiFiCapability' hinting that Apple may combine Li-Fi with iPhones in its forthcoming future.

Conclusion

Li-Fi technology may not replace completely Wi-Fi, but both the technologies able to use complementary to create more sustainable, efficient, and future-proof transmission networks.

References:

- [1] <https://en.wikipedia.org/wiki/Li-Fi>
- [2] <http://www.lifi-centre.com/about-li-fi/what-is-li-fi-technology/>

- [3] <http://www.rfwireless-world.com/Terminology/LiFi-vs-WiFi.html>
- [4] <https://www.techopedia.com/7/31772/technology-trends/>
- [5] S. Kumar Subhajit and Choudhury Leena Shah, Wi-Fi and HOTSPOTS: Emerging WLAN Technology in Indian Context 2nd
- [6] International CALIBER-2004, New Delhi, 11-13 February, 2004
- [7] Wei LIU, 2 Yuhua YAN Application of ZigBee Wireless Sensor Network in Smart Home System, June 2011.
- [8] S. V. S. Rama Krishnam Raju, Kahkashan Tabassum, Dr. A. Damodaram A Strategy to Provide Robust and Seamless Data Transmission in
- [9] Broadband Wireless Networks, December 2012.
- [10] C. Jayasri, K.R. Vinothini, Chitravalavan Mobile Based Data Acquisition System for Wireless Sensor Networks February 2013.